

SBB-12

REVISIONS	
DESCRIPTION	DATE
Release	15 JAN 2015

5/16-18 x 1" SS STUD
5/16-18 SERATED FLANGE NUT

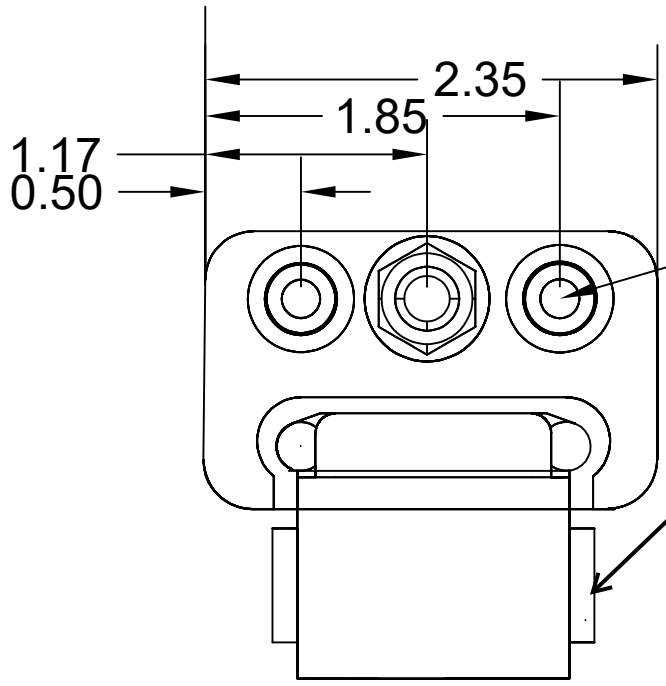
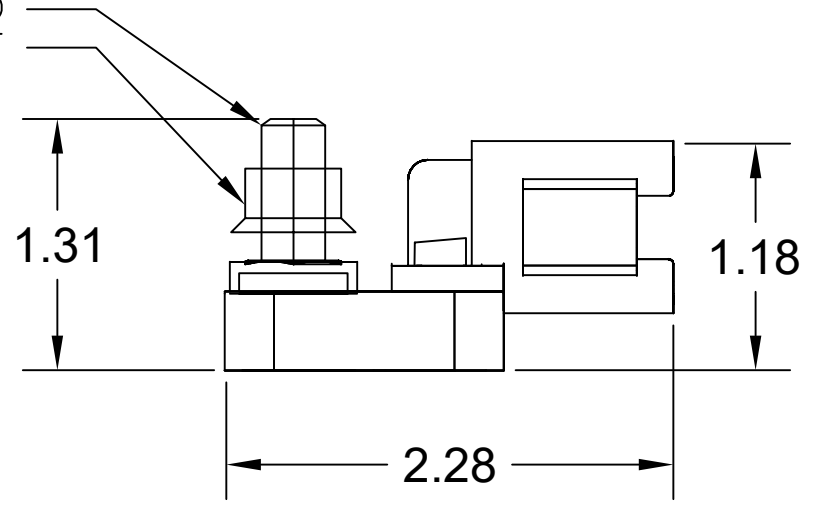

MOUNTING HOLE FOR #10 PAN HEAD

DTF13-12PA

RATINGS: 150A @ 48V DC PER HALF, 13A PER CONTACT
STUD: 1 @ 5/16-18 STAINLESS STEEL
CONNECTOR: SEALED TO IP67
IGNITION PROTECTED: SAE J1171
DEUTSCH MATING CONNECTOR 1: DT06-12SA
AMPHENOL MATING CONNECTOR 1: AT06-12SA
MOLEX MATING CONNECTOR 1: 93445-6212
BUS MATERIAL: C1100 ELECTROLYTIC COPPER
BASE: REPTU - INJECTION MOLDED - BLACK



WWW.SEALEDUSSBAR.COM
The best protection for your electrical connections

THIS DRAWING IS THE PROPERTY OF SORENSON LIGHTED CONTROLS, INC. A FLORIDA CORPORATION. ALL RIGHTS RESERVED. THIS DRAWING AND INFORMATION CONTAINED MAY NOT BE COPIED OR DISCLOSED TO OTHERS WITHOUT THE WRITTEN PERMISSION OF SORENSON LIGHTED CONTROLS, INC.