

Series 16, 17

Features

- Snap fits into 1.450" x .830" panel cutout
- Incandescent and neon illumination
- Single or dual lenses
- Dummy (hole plugs) available

Specifications

- Body Material: Nylon
- Lens Material: Polycarbonate
- Wire Gauge: 18 ga.
- Panel Thickness: .030 to .240
- Certifications: Contact Us

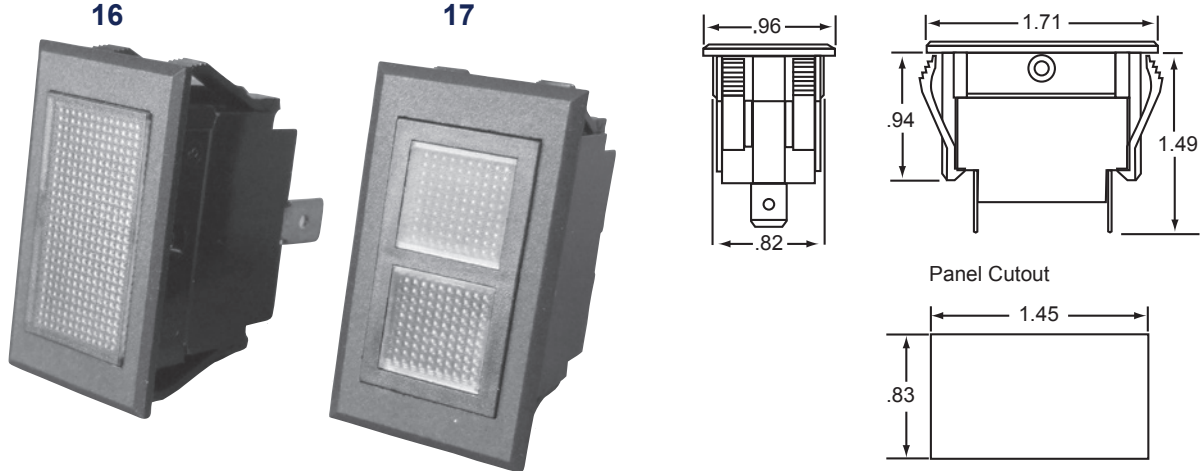

Rectangular Indicators

Series	Lamp	Termination	Base	Bezel	Lens								
XX	XX	- X	- X	X	-	XXX		X	X				
16	Voltage N/A	Type DUMMY	Code 00	Style N/A	Code 0	Color Std.	Code 0	Finish Matte Black	Code 5	Style Single Translucent	Code 131	Color Red	Plain 1
17	6	INCAND	32	.187 Tabs	3			Matte White	6	Single Diamond	133	Amber	2
	14	INCAND	35	.250 Tabs	4					Single Fine Diamond	137	Clear	3
	28	INCAND	39	Solder	5							Green	4
	125	NEON	50							Dual Translucent	141	Blue	5
	250	NEON	52							Dual Fine Diamond	147	White	6
	Custom		XX									Black	7
												Color Marked	
												Red	A
												Amber	B
												Clear	C
												Green	D
												Blue	E
												White	F

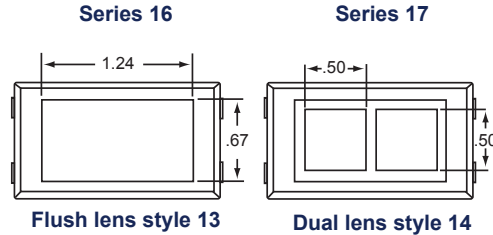

Series	Code
16	0
17	Select 2nd lens color

White is Translucent
Clear is Transparent

Additional Options Available:
Contact sales@solico.com